

500B

40kHz to 200kHz

The Model 500B is a heavy duty cast bronze keel mount transducer for commercial vessels. The 500B is available in 50 kHz and other frequencies. The 500B is supplied with a heavy duty cable.



Model 500B

Options:

- Temperature sensor.
- Custom element configurations.
- Impedance matching.
- Different style connectors.
- Connector boot.

Applications:

- Fiberglass or wood hulls only.
- Not for use on Aluminum hulls.

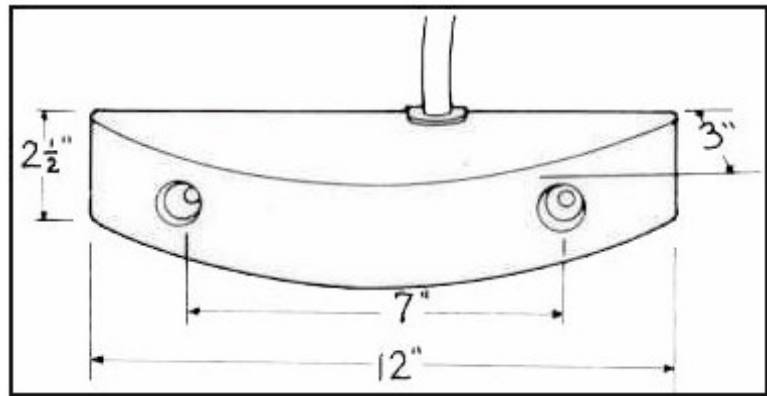

500B – Dimensional Data Not To Scale

Specifications:

- Housing material: Bronze
- Standard cable length: 30 feet.
- Weight: Bronze – 11.5 lbs.

Performance Data

| FREQUENCY (kHz) | BEAM WIDTH (degrees @ -3db) | ELEMENT SIZE (inches) | CAPACITANCE (pf) | IMPEDANCE (ohms) | TRANSMIT RESPONSE (db) | RECEIVE RESPONSE (-db) | POWER RATING, RMS (watts) | COMMENT |
|-----------------|-----------------------------|-----------------------|------------------|------------------|------------------------|------------------------|---------------------------|---------|
| | | | NOTE (1) | NOTE (2) | NOTE (3) | NOTE (4) | | |
| 200 | 9 | 2.0 | 2185 | 385 | 165 | -186 | 600 | |
| 50 | 36 | 2.3 | 8500 | 180 | 165 | -180 | 600 | |
| 40 | 42 | 2.1 | 1800 | 850 | 162 | -172 | 700 | |

(1) with standard length cable. (2) equivalent series R in water. (3) the source level generated by one watt input. (4) the open circuit RMS voltage generated by a pressure of one microbar.