

Installation Instructions

TRANSOM MOUNTED TRANSDUCER

MODEL 250 and 265

IMPORTANT – PLEASE READ THESE INSTRUCTIONS COMPLETELY BEFORE PROCEEDING WITH THE INSTALLATION OF THE TRANSOM MOUNTED TRANSDUCER.

WARNING: NEVER USE SOLVENTS!

Cleaners, gasoline, paint, sealant and other products may contain strong solvents, which may attack many plastics dramatically reducing their strength.

MOUNTING LOCATION

To obtain the best performance with a transom mounted transducer requires consideration of several factors; hull type (fiberglass or aluminum), dead rise, propeller location, boat speed, etc.

The important thing to remember is that the transducer must have a bubble-free, non-turbulent flow of water across its bottom face. Some experimentation might be necessary before a satisfactory position is found. Using the following rules will reduce the need to relocate;

- Select a location as near to the keel or centerline of the boat as possible.
- Do not locate behind hull protrusions (water inlet/outlet fittings), strakes, ribs, etc.
- If boat is aluminum with exposed rivet heads, avoid mounting in line with these rivets. Also avoid weld seams.

INSTALLATION

WARNING: Always wear the proper safety goggles, dust mask and clothing during the installation procedure.

To get a true vertical depth reading, the transducer should be mounted parallel to the water line. A 10° variation is acceptable. If the hull is reasonably flat with a dead rise of 10° or less, mount as shown in Figure 1a. If dead rise is greater than 10°, mount as shown in Figure 1b.

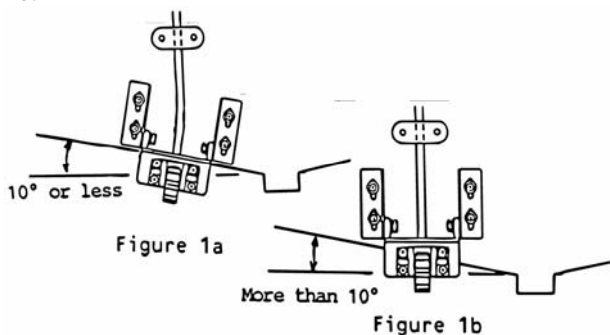

1. Assemble the stainless steel brackets to the transducer using the hardware furnished. Do not tighten until final adjustments are made.
2. Place assembly on transom at selected location with the front of the transducer extending 1/2" to 5/8" below the bottom of the boat and with the front part against the transom. See Figure 2. The least amount that the transducer extends below the bottom is desirable. If too low, spray and turbulence will occur.

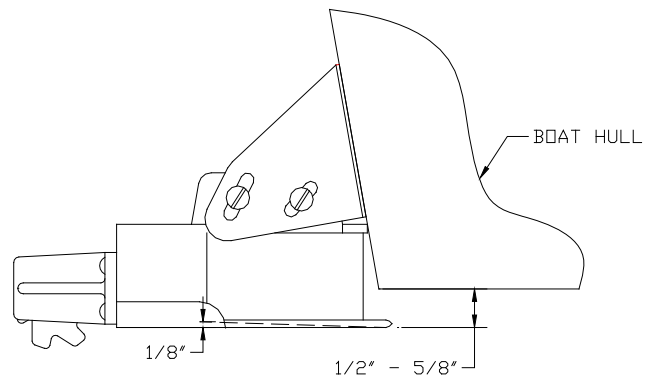

Figure 2 – Mounting the Transducer.

3. With transducer in place, mark location of slotted holes in brackets.
4. Drill in center of slot outline with a 9/64" (3.5mm) drill, 3/4" (19mm) deep.
5. Fasten the transducer to the transom using the #10 x 3/4" screws. See Figure 3.

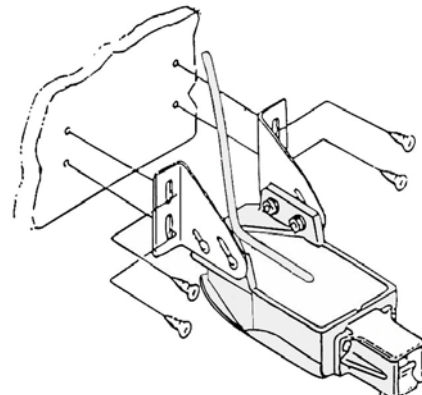

Figure 3 – Fastening brackets to transom

Installation Instructions

TRANSOM MOUNTED TRANSDUCER

MODEL 250 and 265

6. Before final tightening the 4 screws holding the brackets to the transducer, tip the rear edge down approximately 1/8" as shown in Figure 2.

7. Tighten all screws.

CAUTION. DO NOT use any thread locking compound on the screws. Most products such as LOCTITE contain chemicals that attack and weaken plastics.

IMPORTANT. There should be no gap between the brackets and the transducer. A wide space between these parts will cause stress on the transducer mounting ears and result in breakage with time.

8. In running the cable to the sounder, avoid proximity to other wiring on the boat, particularly ignition and alternator cables. They can be a source of noise on the sounder display.

9. Secure the transducer cable with clamps or ties. **DO NOT REMOVE PLUG. DO NOT CUT OR SPLICE CABLE.** A cable cap, Si-Tex 10-112 can be used to seal any hole through the transom or bulkhead.

only a light coat after thoroughly cleaning the face. Do not use any solvents. If the transducer has a speed sensor (paddle wheel), it also can be painted.

If the boat is towed on a trailer, the paddle wheel should be restricted from spinning while in transit. Use a rubber band or a piece of tape. If allowed to spin freely in the air stream, the paddle wheel bearings will sustain excessive wear due to lack of lubrication (water).

TESTING

After determining that the depth sounder is working satisfactory with the boat in the water, bring boat up to speed gradually and note if there is any loss of depth reading or indication of "noise" on the display. If so, make gradual turns in both directions and if improvement is noticed as compared to the straight heading, the transducer is getting turbulent or aerated water across its face.

The first corrective action is to loosen the transom screws and lower the transducer 1/8" to 1/4".

If this does not correct the problem, the transducer must be moved to another location, possibly closer to the center of the transom. But first make sure there are not rivet heads or fittings directly forward of the transducer. If moving it to the center does not show improvement, try moving it outward.

Be sure to fill any unused holes with RTV compound or similar sealant.

MAINTENANCE

When used in saltwater, the transducer can quickly attract marine growth. Any deposits on the face will reduce performance. To overcome this, paint the transducer with any good anti-fouling bottom paint. Apply

Installation Instructions

TRANSOM MOUNTED TRANSDUCER

MODEL 250 and 265

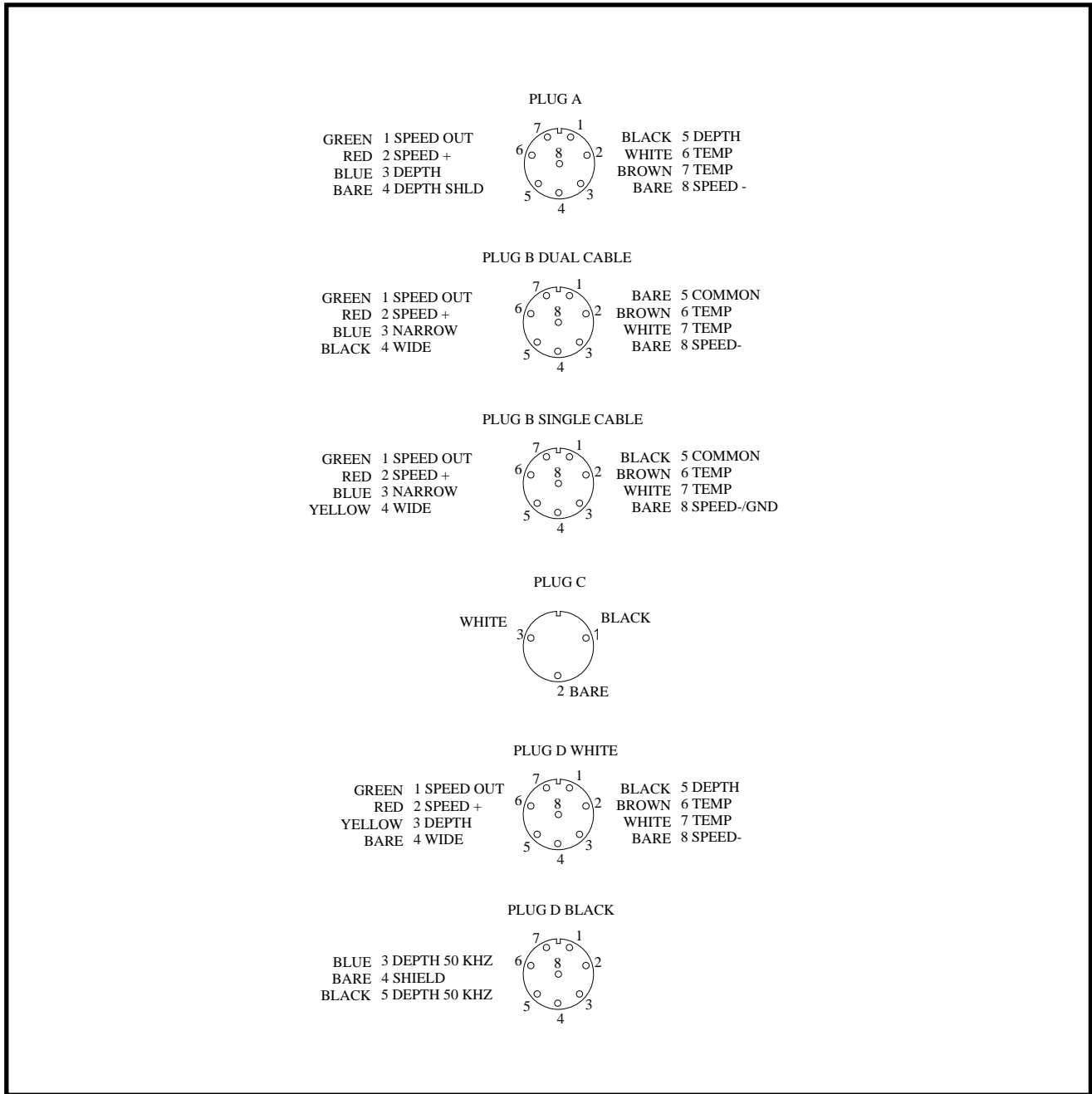

Figure 4 – Plug connections and color code.

PLUG A is used on the following models:
250-50ST, 250-50T8P, 250-120-ST, 250-120T8P, 250-200ST, 250-200T8P, 250-50/200-ST.

PLUG C is used on the following models:
250-120, 250-200.

PLUG B is used on the following models:
250-120STDB.

PLUG D is used on the following models:
250-50/200S